

**PRODUCT SPECIFICATIONS**

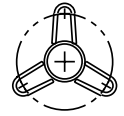

**ANCHOR PATTERN**

96 cm - 1.2 m  
(3) 3/4" Anchors  
Equally spaced on 6.80 bolt center

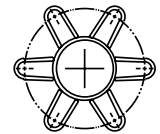

**ANCHOR PATTERN 2**

1.8 m  
(6) 3/4" Anchors  
Equally spaced on 8.50 bolt center

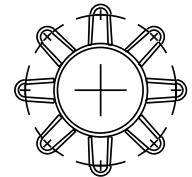

**ANCHOR PATTERN 3**

2.4 m  
(8) 3/4" Anchors  
Equally spaced on 10.68 bolt center

Each model includes an anchor bolt kit.



## King Post Mounts

The ASC Signal King Post Mounts are specifically designed for our 96 cm, 1.2 m, 1.8 m and 2.4 m reflectors. Mechanically tested and field proven, these fully adjustable mounts exceed the performance requirements of demanding commercial applications. When assembled and mounted according to the installation instructions provided, these King Post Mounts are engineered to withstand 125 mph winds.

For accuracy and ease of assembly, each mount is accompanied with an anchor pattern template and all necessary installation hardware.

ASC Signal King Post Mounts and hardware are constructed from heavy-gauge steel and are hot-dip galvanized for maximum environmental protection.

Model	Antenna Size	King Post O.D.	Anchors and Pattern Number	Anchor and Bolt Diameter
610012901	96 cm - 1.2 m	73 mm (2.88")	3 Anchors, Pattern #1	6.80"
610013001	1.8 m	114 mm (4.50")	6 Anchors, Pattern #2	8.50"
610013101	2.4 m	168 mm (6.635")	8 Anchors, Pattern #3	10.68"

**SPECIFICATIONS**

96 cm, 1.2 m, 1.8 m and 2.4 m King Post Mounts

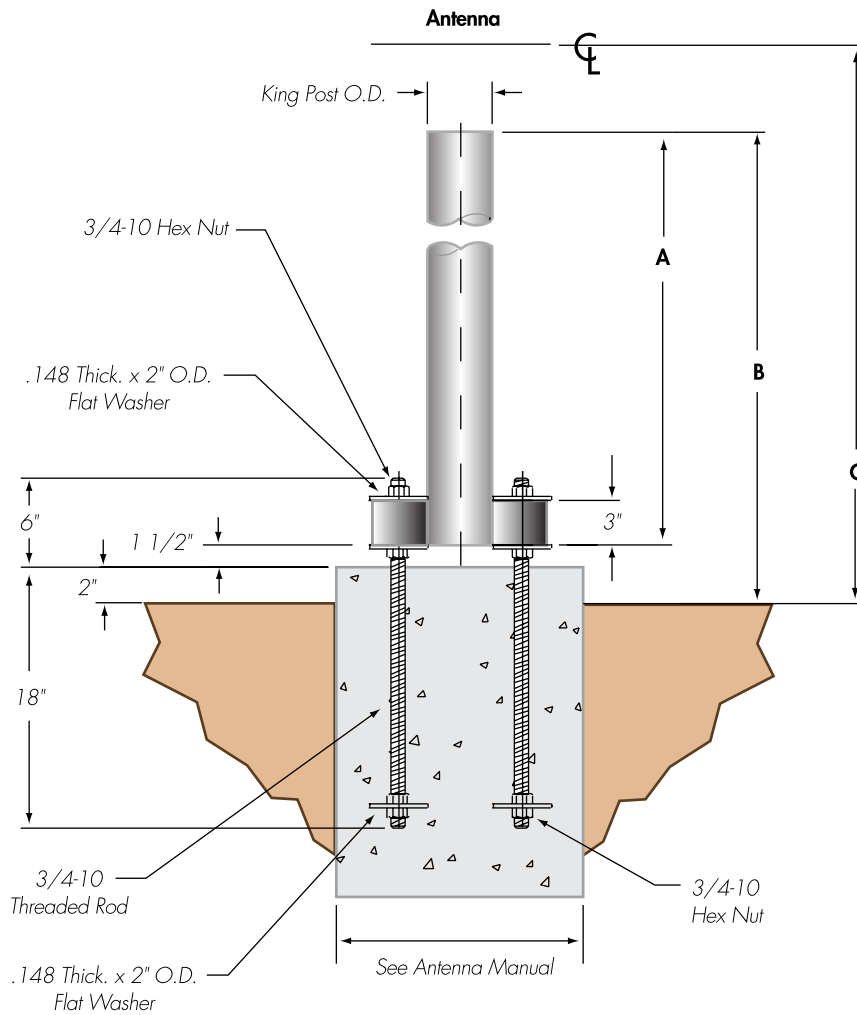

Model	Dimensions			Allowable Windspeed Exposure B	Allowable Windspeed Exposure C
	A	B	C		
610012901	30.0"	33.5"	40.9"	125 mph	118 mph
610013001	46.5"	50.0"	55.5"	125 mph	116 mph
610013101	60.0"	63.5"	69.5"	125 mph	107 mph



ASC Signal Corporation  
1315 Industrial Park Drive  
Smithfield, NC 27577  
USA

Telephone: +1-919-934-9711

Internet: [www.ascsignal.com](http://www.ascsignal.com)

All designs, specifications and availabilities of products and services presented in this bulletin are subject to change without notice.

ASC-VSAT16.1

© 2007 ASC Signal Corporation